

Project: Covered Journals

DESIGNER: JENNIFER PAGANELLI

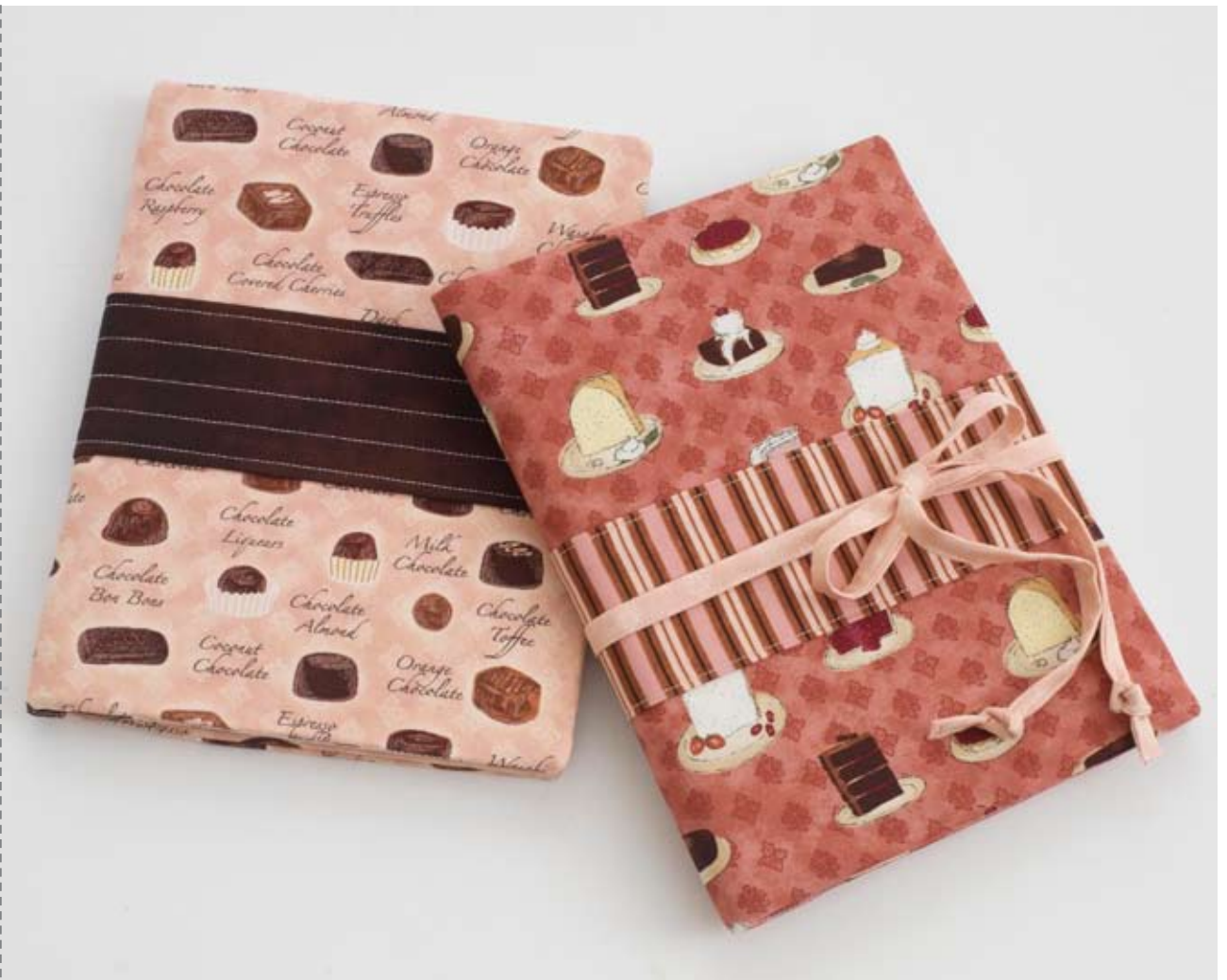

Project: Covered Journals

Materials

- $\frac{1}{2}$ yard *each* novelty print (journal cover) and white flannel (interlining)
- 1 or 2 — $\frac{1}{8}$ yard pieces contrasting prints (band, tie)

Measurements include $\frac{1}{4}$ " seam allowances. Sew with right sides together unless otherwise stated.

Cut Fabrics

Cut pieces in the following order.

From cover print and from flannel, cut:

- 1 — $14 \times 29\frac{1}{2}$ " rectangle

From contrasting prints, cut:

- 1 — $1\frac{1}{2} \times 42$ " strip
- 1 — $6 \times 29\frac{1}{2}$ " strip

Assemble Cover

1. Fold contrasting print $6 \times 29\frac{1}{2}$ " strip in half; sew along long edges (**Diagram 1**). Turn right side out and press to make band.
2. Layer cover print and flannel $14 \times 29\frac{1}{2}$ " rectangles wrong sides together. Position band on right side of cover print rectangle; topstitch long edges of band in place (**Diagram 2**). Zigzag-stitch around all edges of rectangles.
3. Turn under short edges of layered rectangles $\frac{3}{4}$ "; topstitch close to edges. Then fold each short edge $6\frac{1}{2}$ " toward center to make a 14×15 " rectangle. Sew 2" from each long edge (**Diagram 3**).

4. Turn under ends $\frac{1}{4}$ " on contrasting print $1\frac{1}{2} \times 42$ " strip (**Diagram 4**). Press strip in half lengthwise with wrong side inside. Open up fold and press under $\frac{1}{4}$ " along long edges. Re-press strip along center fold; stitch close to both long edges to make tie.

Finish Journal Cover

1. To reduce bulk, trim upper layer only of cover seam allowances as shown. Topstitch tie in place to complete journal cover (**Diagram 5**). Turn cover right side out and insert $7\frac{1}{2} \times 9\frac{3}{4}$ " composition book.

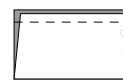

DIAGRAM 1

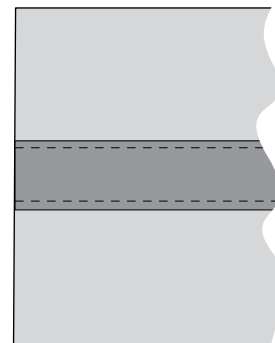

DIAGRAM 2

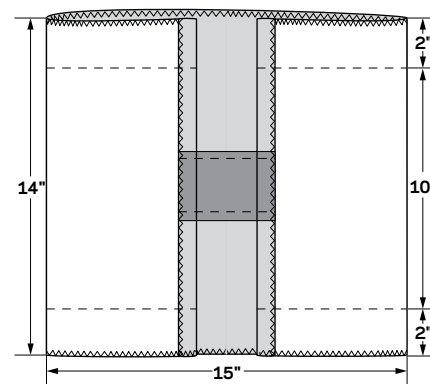

DIAGRAM 3

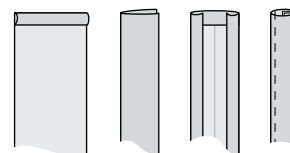

DIAGRAM 4

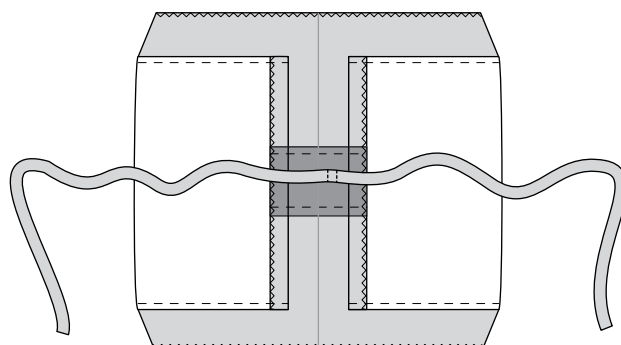

DIAGRAM 5